

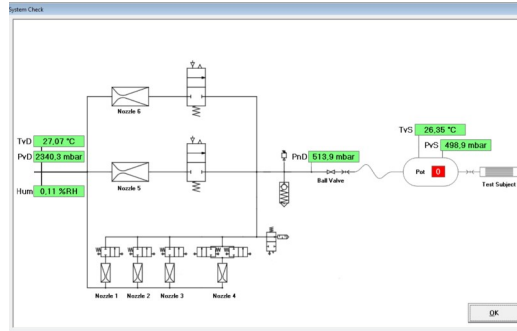

## High Accuracy Airflow Test Stand

### ATS

- Use of sonic nozzles
- Pressure control
- Relative pressure at specimen
  - 1.1 to 1.5  $P_{abs}$
  - Optional up to 3,5x $P_{abs}$
- Mass flow
  - 5,0 - 750 kg/h
- Accuracy
  - $\pm 1,0\%$  of measuring range
  - $\pm 0,5\%$  optional
- Easy to use
- Export to Excel, ASCII or SAP system



### Overview

**MAUL-THEET** Air Flow Measurement solutions offer the possibility to measure the mass flow of turbine blades, sheet metal inputs and other specimens like e.g. burners.

The solution contains a small form factor sonic nozzle test bench including a PC for automated operation.

### Cost-Reduction

Quality Test Solutions by MAUL-THEET make it possible to do your tests during the process of production. Hence, it is possible to detect tolerance deviations earlier, which allows you to do reworking in time.

### Time-Reduction

To reduce the test time, we implemented automation for the following processes:

- pressure controlling
- nozzle selection dependent on nominal mass flow
- calculation of reduced mass flows according to company standards

With that automation the measurement task transforms to an one-click operation.

### Simplicity

Our philosophy of design is: high accuracy at simplest usability.

The test bench user interface is made to be operated by production personal without any skills at measuring air flow. This is proved every day at our customers in the turbine industry.

### Measurement Method

The use of sonic nozzles ensures high accuracy results at long term stable measuring equipment.



## Software

The main focus while developing our software was to make it easy-to-use, but although very functional. The result of that is a software, that can be used by nearly everybody, for simple measurement tasks. The following key functionalities are available:

- Serial Measurement (with master blade measurements)
- R&D Test Measurement
- Task Management
- Test-Object Management (Blade Management)
- Analysis & Reporting
- User & Rights Management

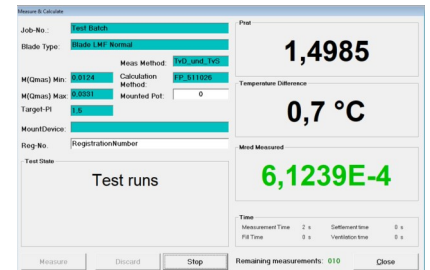

## Database

All data is saved in a local database, which makes our software easy extensible. On request we also offer a centralized server solution.

## Analysis & Reporting

Beside export of the data to Excel or SAP, it is also possible to directly print reports or labels or do analysis tasks like calculation of mass flow spreading through different tasks or area-allocation.

## Remote Administration

We offer a discrete application for remote administration, which makes it is possible to change settings or define tasks on the test benches, from within the office, through a network connection.

## Applications

- Component testing on gas turbines
  - Air cooled turbine blades
  - Burners with multiple fuels paths
- Determination of effective flow areas
  - Drilling holes
  - Complex specimen
- Calibration of mass flow devices

## Complete System

We deliver complete systems, from test bench to software, from one source.